

# Construction Material Technology Supporting Social Infrastructure<sup>†</sup>

KASUGA Masami<sup>\*1</sup> HASHIMOTO Osami<sup>\*2</sup> NAKAMURA Nobuyuki<sup>\*3</sup>

## Abstract:

*Steel products play an important role as construction materials by taking advantage of a number of outstanding features, which include easy formability, high strength combined with high earthquake resistance based on excellent plastic deformation performance, recyclability and so forth. This paper describes an outline of representative new construction products and JFE Steel's approach to product development based on trends and needs in the social environment.*

## 1. Introduction

Construction materials are an enormous market in Japan, accounting for half of total steel demand, and therefore are an extremely important field for steel makers in deciding business strategy. JFE Steel's involvement in the construction materials business dates from the 1950s, when the company began building coastal steel works and peripheral facilities such as dormitories, employee housing, hospitals, and gymnasiums. The prototypes of today's key products such as steel pipe piles, steel sheet piles (especially for steel pipe sheet pile foundations), and H-shapes were all born during this period. At the same time, the company also developed a wide range of use technologies for construction materials, including construction technologies for heavy structures such as blast furnace foundations, port and harbor construction technologies, technologies for improving soft stratum, and construction technologies for steel structures and buildings.

Since that period, JFE Steel and its group companies have developed construction materials which respond to

diverse social needs, including changes in the construction environment (low noise, low vibration), advanced earthquake resistance requirements occasioned by the 1995 Kobe Earthquake, reduced construction costs, and environment-friendliness, and have commercialized a large number of products.

This paper describes the development of construction materials made by JFE Steel in the respective fields of civil engineering and construction, focusing on Only 1 and No.1 products.

## 2. Construction Materials for Civil Engineering

### 2.1 Highways and Railways

In the highway/railway field, JFE Steel has developed and popularized construction material use technologies centering on steel pipe piles for bridge foundations and steel pipe sheet pile foundations. Although conventional pile driving was originally the primary method of executing pipe pile works, JFE Steel developed various new methods in response to noise and vibration regulations, including the inner excavation method for steel pipe piles, the composite pile method composed of steel pipe and soil cement, and the rotary pile driving method,<sup>1)</sup> and also developed methods and materials for large-scale bridge construction, as represented by the steel pipe sheet pile composite foundation.<sup>2)</sup>

To solve the problems of chronic traffic congestion and division of urban areas by roads and railways, JFE Steel has given a renewed attention to the use of underground space. Methods of utilizing underground space include the open excavation method using sheet piles

<sup>†</sup> Originally published in *JFE GIHO* No. 2 (Nov. 2003), p. 63–77



<sup>\*1</sup> General Manager,  
Construction Engineering Services Dept.,  
Construction Material & Services Center,  
JFE Steel



<sup>\*2</sup> Manager,  
Civil Engineering Sec.,  
Construction Engineering Services Dept.,  
Construction Material & Services Center,  
JFE Steel



<sup>\*3</sup> Manager,  
Construction Engineering Sec.,  
Construction Engineering Services Dept.,  
Construction Material & Services Center,  
JFE Steel

and the closed non-excavation method with steel pipe sheet piles (pipe loop method). However, they are not necessarily adequate for executing work in urban areas where uninterrupted road/rail service are essential. JFE Steel has therefore devoted a great effort to the development of construction materials for restricted land areas and low spaces. Representative examples include K-Domeru, a retaining material for low spaces,<sup>3)</sup> JES shape, a material for long-distance underpass construction,<sup>4)</sup> and High Meca-Neji, a mechanical joint of steel pipe piles for underpinnings.<sup>5)</sup>

**2.1.1 HYSC pile method<sup>6)</sup>**

The HYSC pile method, as shown in Fig. 1 and Photo 1, is a composite pile method combining a ribbed steel pipe pile and soil cement column which is constructed by injecting, mixing, and stirring cement-milk in the soil of the original ground and sinking the steel pipe pile simultaneously or thereafter, forming a single unit.

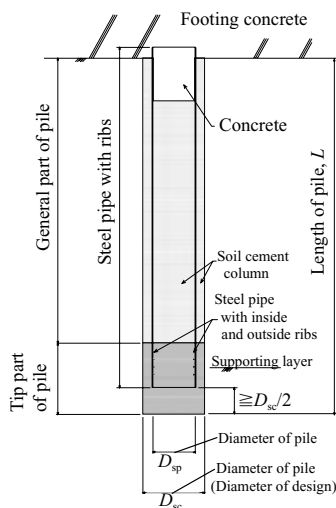

Fig. 1 Outline figure of HYSC pile



Photo 1 HYSC pile

The main advantages of the HYSC pile method are as follows:

- (1) Low Vibration, Low Noise Method with Surplus Soil Generation Minimized

Because the original ground soil is used as part of the pile body (soil cement column), little surplus soil is generated in comparison with cast-in-place concrete piles and other embedded pile methods.

- (2) High Bearing Performance

Because this method does not weaken the original ground, when considering the bearing force, the diameter of the soil cement column can be designed as the pile diameter (design diameter). As a result, the HYSC method demonstrates excellent bearing performance in comparison with conventional piles, making it possible to reduce the number of piles and use a more compact footing design.

Based on the fact that the 2002 revision of Specifications for Highway Bridges lists this method as a new pile method,<sup>7)</sup> it is expected to be adopted in numerous highway bridge foundations in the future.

**2.1.2 Steel pipe sheet pile composite foundation method**

The steel pipe sheet pile composite foundation is a new foundation method developed for large bridges. This type of foundation incorporates new improvements in the conventional steel pipe sheet pile foundation. As shown in Fig. 2, it comprises a composite pile, which consists of a steel-concrete composite structure and a cast-in-place concrete pile, and a high strength pipe-junction which is used to interconnect these composite piles. The features of these three components are described below:

- (1) High Strength Pipe-junction

As shown in Fig. 3, the high strength pipe-junction is based on the P-P type junction for steel pipe sheet pile foundations,<sup>8)</sup> but substantially improves the

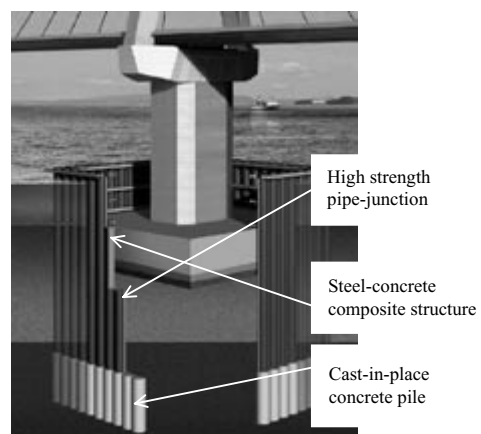

Fig. 2 Schema of steel pipe sheet pile composite foundation method

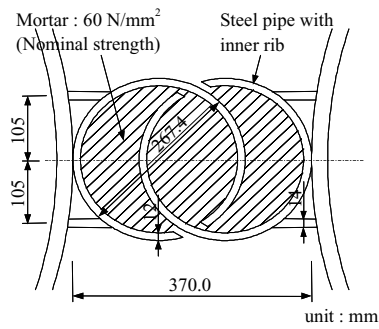

Fig. 3 High strength pipe-junction

shear strength of the conventional junction by incorporating the following three improvements: (a) Use of steel pipes with inner ribs in the junction pipes, (b) use of high strength mortar, and (c) increased outer diameter of the junction pipes from 165.2 mm to 267.4 mm. Increasing the outer diameter of the junction pipes is also expected to improve ease-of-use in cleaning the interiors of the junction pipes.

(2) Steel-Concrete Composite Structure

The steel-concrete composite structure is a structure comprising a steel pipe filled with concrete. Because the pipes are provided with inner ribs, the effect of a composite structure can be expected.

(3) Cast-in-place Concrete Pile

In cases where adequate driving of the steel pipe sheet pile in the bearing stratum is difficult, it is possible to compensate for the insufficient vertical bearing capacity with no loss in ease-of-use by using the cast-in-place concrete pile as a bearing stratum.

By applying the steel pipe sheet pile composite foundation, foundation rigidity can be improved and the necessary vertical bearing performance secured, making it possible to reduce plan dimensions in comparison with the conventional steel pipe sheet pile foundation method. As a result, the new method is particularly economical in large bridges, where the ratio of foundation plan dimensions to pier plan dimensions tends to be large when using a conventional steel pipe sheet pile foundation.

### 2.1.3 Construction materials for underground structures

(1) K-Domeru

K-Domeru is a steel retaining wall in which straight web type piling used in the construction of cellular steel sheet pile cofferdams and steel plates or shapes (CT, H) are combined by welding. Because the cross-sectional profile is a continuous arrangement of H-shape forms, high sectional rigidity can be obtained with a thin wall thickness in comparison with conventional methods such as the soil cement wall. Moreover, because execution is possible



Photo 2 H-shaped steel sheet pile(K-Domeru)

with a small-scale self-propelled jacking equipment, K-Domeru is effective in restricted environments, for example, in construction adjacent to roads or railways and under low girders (**Photo 2**).

(2) JES Shape

The HEP (high speed element pull) and JES (jointed element structure) construction method is a practical non-excavation type construction method for roads, water channels, pedestrian underpasses, and similar structures which must cross under existing rail lines or roadways, and was realized through joint development by East Japan Railway Company and Tekken Corp. For the JES Shape, which is the main component in this method, JFE Steel developed a hot rolled shape steel with sufficient fatigue strength for cyclical loads such as trains based on an agreement with J-Tec Co., a specialized construction company executing work by this method.

**Figure 4** shows a schematic outline of the JES construction method. A tunnel structure is constructed by first tunneling, pulling the steel element in the same path as the special joint (JES joint), and then filling the joints with grout and elements with concrete. Among advantages, the transverse length under rail lines is not limited and work has less influence on track surface during the construction period, making the JES method an easy, economical construction method. As the tunnel cross-section, a round shape can be used in addition to the

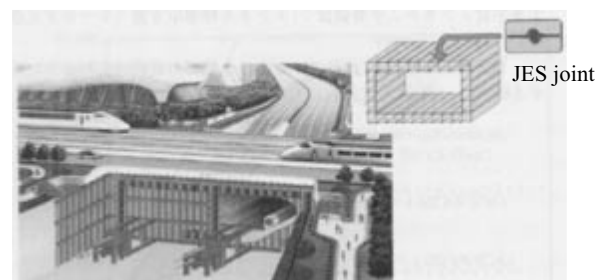

Fig. 4 Outline of JES construction method



Photo 3 Jointed element structure-shaped steel (Jointed element structure method)

general rectangular shape (**Photo 3**).

## 2.2 Ports and Harbors

Ports and harbors in Japan are frequently constructed in areas with weak alluvial ground, where steel easily demonstrates its numerous advantages, including high performance in anchoring in deep bearing strata and high bending/shear properties, which are necessary to resist horizontal external forces such as earthquakes and waves. As examples, the cantilever type, equipped with anchorage type, and equipped with coupled-pile anchorage type seawall are widely recognized as general revetment and pier structures for weak ground. Increasingly important JFE Steel's products include double-walled steel (pipe) pile structures and steel sheet pile cellular-bulkhead structures as structural types which utilize the shearing resistance of the ground, and more recently, the strutted frame method, which is a rational structural method for deep water and resistance to large horizontal external forces such as high waves.<sup>9)</sup>

Among new fields, there is now an active trend toward construction of marine-area waste landfills due to the recent shortage of conventional landfill sites. Here, JFE Steel has a growing supply record in water barrier wall construction using steel (pipe) sheet piles.<sup>10)</sup>

### (1) Strutted Frame Method

The strutted frame (panel point strut) method (**Photo 4**) is a construction method in which the rigidity of a rigid frame of steel pipe piles and steel pipe sheet piles is reinforced with struts. This method effectively utilizes the vertical and horizontal supporting capacity of the ground by distributing external forces acting on the structure in the vertical and horizontal directions, making it possible to realize high horizontal rigidity. In recent years, upkeep and repair of existing facilities have become key words, and there has been an increasing tendency to improve existing quay walls where construction land is limited. By combining various components such as piles and struts, this method makes it possible to select the structural form best suited to site conditions and min-



Photo 4 Strutted frame quay-wall structure

imize the occupied width in comparison with conventional methods, thus demonstrating true value under restrictive conditions.

### (2) Steel Water Barrier Wall Using Steel (Pipe) Sheet Pile

Because steel itself is impermeable to water, in construction of steel (pipe) sheet pile water barriers for marine-area landfills, leakage is limited to the joints between the sheet piles. Therefore, a water barrier treatment is generally applied by the following methods, depending on the joint configuration.

#### (a) Water barrier method for steel sheet piles

As the water cutoff method for leaks at joints in sheet piles, a water-absorbent expansive cutoff material composed of a special polymer resin is coated on the piles before driving and allowed to cure and harden for several hours to about one day. The piles are then fitted together and driven. Because the cutoff material absorbs water and expands in the presence of water, it swells to fill gaps in the joints, securing a water barrier property (**Photo 5**).

#### (b) Water barrier method for steel pipe sheet piles

Steel pipe sheet piles are a material in which joints are welded to the sides of a pipe. The joint shapes are mainly of the three types shown in **Fig. 5**. As the water barrier method, after the piles



Photo 5 Steel sheet pile joints with polymer seals swelled with water

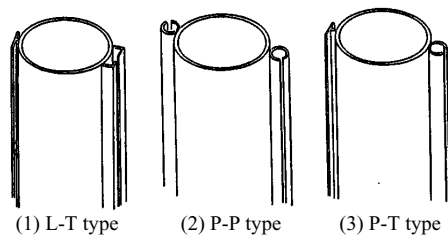

Fig. 5 Type of steel pipe sheet pile joint



Fig. 6 Mechanical joints

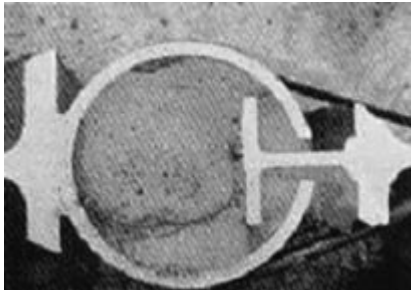

Photo 6 T-P joints of steel pipe sheet pile with mortar

are fitted together and driven, earth and sand which have penetrated the joint are removed with a water jet or similar device, and the space in the joint is filled with a water cut-off mortar (**Photo 6**). When mortar is to be filled in shallow parts of the pile above the sea bottom, a fine nylon bag called a mortar jacket is first inserted to stop leaks from slits in the joints, and the mortar is then injected into the jacket with a pump.

### 2.3 Mountain Improvement Works

Steel pipe piles for landslide prevention may be mentioned as a representative steel product in this field. Landslide is a phenomenon in which unstable lumps of earth slide down an inclined slip surface due to gravity, rain, etc. As a typical countermeasure, steel pipe piles are driven to the immobile earth below the slip surface and fixed to prevent sliding. Because construction sites are located in mountains and narrow land areas with numerous restrictions on transportation and construction equipment, short steel pipe piles must be joined by field welding in many cases. As other problems, for reasons of economy, heavy-walled pipe piles are used to reduce the number of piles, but this requires considerable time for field welding, and work is easily affected by weather.

As a method of solving these problems, high strength steel of tensile strength 570 N/mm<sup>2</sup> class (SM570 equivalent) has been used recently in an increasing number of cases.<sup>11)</sup> When used in combination with a threaded mechanical joint such as Nejiru,<sup>12)</sup> as shown in **Fig. 6**, or Meka-Neji,<sup>13)</sup> work time can be shortened and work control simplified. These mechanical joints possess tensile, compressive, bending, and shear strength equal or superior to that of the pile itself, and do not require spe-

cial materials/equipment or skills for joint fitting work. As an additional advantage, fitting can be completed in a short time. The use of high strength steel materials and mechanical joints contributes to improved ease-of-use and reduced construction costs.

### 2.4 Building Foundations

#### (1) Screw Steel Pipe Pile with Toe Wing “Tsubasa Pile”

Low noise and low vibration are essential conditions for pile driving in urban areas, and disposal of surplus soil is also a problem. Therefore, JFE Steel developed a low noise, low vibration pile driving method called the Tsubasa Pile which causes no soil discharge because the hollow pile is driven into the ground by rotation, by the same principle as a wood screw. Moreover, because the pile also penetrates the hard bearing strata by rotation, this method was first possible by utilizing the high torsional rigidity of steel pipe.

The Tsubasa Pile consists of a steel pipe pile and a toe wing of mutually-intersecting semicircular flat steel plates attached to the leading end of the pile (**Fig. 7**, **Photo 7**). The available size range includes pile outer diameters (OD) of 318.5–1 200 mm and toe wings ( $D_w$ ) 1.5–2.5 times larger than the pile OD (1.5–2.0 times OD in the 600–1 200 mm size range), and can be selected as required by the design. The plate thickness of the toe wing is selected as required by the axial force acting on the pile. As one advantage, manufacture is simple because flat plates are used in the toe wing. For soft ground and liquefied ground, an enlarged-head Tsubasa Pile with an expanded pile head section can be applied (diameter: 400–1 800 mm; approximately 1.5 times larger than the pile OD in the standard section).

With piles in the OD = 318.5–600 mm size range, driving is performed by the pile head holding method using a 3-point type pile driver (**Fig. 8** (a)). With piles of OD  $\geq$  500 mm, driving is by the pile shaft-holding method using a full circumference rotary pile driver (**Fig. 8** (b)). In pile-driving control, bearing strata can be judged easily by measuring the screw torque and penetration depth per screw.

The Tsubasa Pile is a pile driving method which

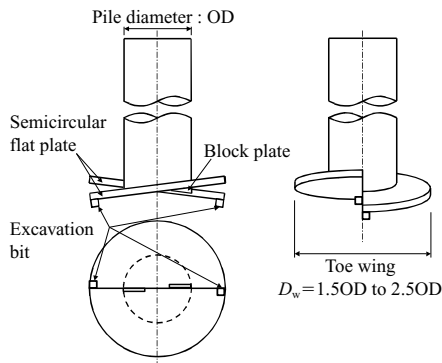

Fig. 7 Composition of Tsubasa Pile



Photo 7 Toe wing

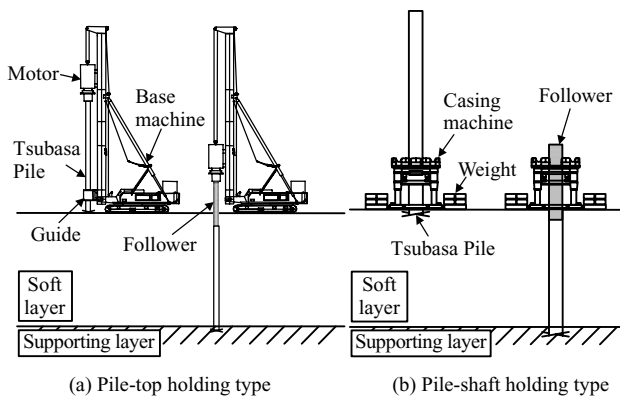

Fig. 8 Construction method

responds to recent environmental problems, in that the pile penetrates the ground by rotation using the toe wing, generating no waste soil.

The Tsubasa Pile was approved by Japan's Minister of Construction in 2002 and received construction technology certification from Public Works Research Center in 2003, and thus can be used in foundations for civil works, mainly in building foundations. Through fiscal year 2002, JFE Steel had supplied a total weight of 31 000 t.

(2) Inner Pile Excavation Method Using Steel Pipe Pile (KING Method)

To expand the use of steel pipe piles in building foundations, JFE Steel undertook the development of an inner excavation/foot guard method for steel pipe piles as a method which is suitable for large diameter and long piles and can be applied with a wide range



Photo 8 Inner pile excavation method of steel pipe (KING method)

of ground types. Commercial use of this technology as the KING method began in 1998 (Photo 8).

In the KING method, an auger is inserted inside a steel pipe pile, and the pile is sunk to the bearing stratum while excavating earth and sand from the leading end, using the pile as a casing. On reaching the bearing stratum, cement-milk is injected into the leading end of the pile to construct an expanded foot guard section, and bearing force is secured when the foot guard hardens.

The KING method has been approved by the Minister of Construction based on the former Building Standards Act, No. 38 for pile diameters up to  $\phi 1\ 000$  mm. From 2001 through 2002, loading tests were carried out with pile diameters of  $\phi 1\ 200$  mm. Applicability to piles exceeding  $\phi 1\ 000$  mm was confirmed, resulting in increasing adoption in actual construction. As of February 2003, the total installed length was 250 000 m and the weight of steel pipe piles exceeded 45 000 t, making the KING method a leading construction technology in the field of building foundations.

3. Building Materials

3.1 High Performance Steel Plates

3.1.1 550 N/mm<sup>2</sup> class TMCP steel plate for building structural use "HBL385"

High strength steel products are required for use in high rise buildings in urban areas. Considering the damage caused by beam-end weld failure during the Kobe Earthquake in 1995, high performance steel products with a low yield ratio (yield point/tensile strength), high toughness, and good weldability are increas-

ingly required in building frames. Recently, there has also been strong pressure to reduce construction costs, reflecting difficult economic conditions.

To meet this complex set of needs, JFE Steel developed a steel plate, HBL385, with a lower limit yield point of 385 N/mm<sup>2</sup> as a high strength steel product which provides an excellent combination of economy, earthquake resistance, and weldability.<sup>14)</sup> This steel was approved by the Minister of Land, Infrastructure and Transport in Apr. 2002 under Article 37 of the Building Standards Act. JFE Steel made HBL385 available for the first time in the world by applying the state of art TMCP technology using the advanced on-line accelerated cooling device *Super-OLAC*, which is one of JFE Steel's proudest technical accomplishments.

The available thickness range of HBL385 is from 19 mm to 100 mm. The lower limit of the yield point is 385 N/mm<sup>2</sup> (range: 120 N/mm<sup>2</sup>), the lower limit of tensile strength is 550 N/mm<sup>2</sup> (range: 120 N/mm<sup>2</sup>), the yield ratio is 80% or less, and Charpy absorbed energy at 0°C is 70 J or higher. The chemical composition of the steel realizes a low carbon equivalent.

When examining the yield point strength grades of steel products for construction currently being used, the values are 235 N/mm<sup>2</sup>, 325 N/mm<sup>2</sup>, 355 N/mm<sup>2</sup>, and 440 N/mm<sup>2</sup>. Generally, high strength is demanded in steel materials as the building height of high-rise structures increases because high strength materials make it possible to decrease steel weight by reducing the required sections of members, and also lessens the burden of steel frame fabrication, transportation, and erection work. Although the conventional SA440 is a high strength product with outstanding performance, higher steel material costs are unavoidable due to alloy addition and the complicated heat treatment process after rolling. As an additional difficulty, strict control of welding during steel frame fabrication is necessary. For these reasons, 325 N/mm<sup>2</sup> class had become the standard steel material for high-rise constructions.

JFE Steel possesses world class manufacturing and quality control technologies for TMCP steel, as well as an extensive supply record. Utilizing these capabilities, the company realized low cost combined with high strength in the steel shown in **Fig. 9** by high accuracy control of rolling and accelerated cooling conditions, making it possible to increase strength while minimizing the use of expensive alloying elements. Despite the high strength of the material, HBL385 also exhibits similar weldability properties to those of HBL325 and 355, therefore, welding costs in frame fabrication can be held to a low level. The chemical composition of HBL385 provides excellent weld impact properties. Strict performance requirements for high heat input welding during frame fabrication can also be satisfied.

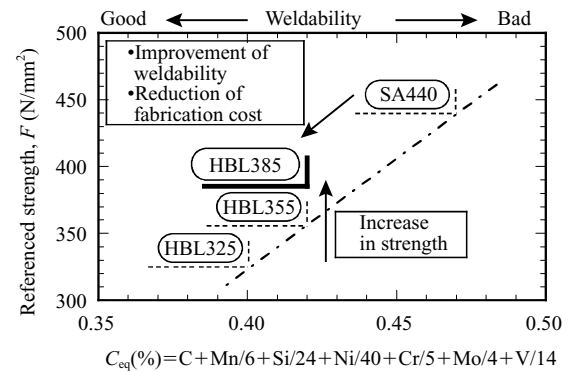

Fig. 9 Concept of the developed HBL385

HBL385 is a high performance, high tensile strength steel material which offers the highest total performance in terms of strength, economy, weldability, and earthquake resistance among YP235–440 N/mm<sup>2</sup> class steel products. This new product expands design flexibility and makes it possible to meet diversified market requirements by applying 385 N/mm<sup>2</sup> as the standard yield point grade for steel materials for high-rise constructions.

### 3.1.2 High strength plates with excellent weldability and their welding technology

High performance 590 N/mm<sup>2</sup> class high strength steel was developed by JFE Steel in advance of other makers in the world. This material, which makes practical use of the Use Technology Guidelines of the Ministry of Construction's Comprehensive Technology Development Project, is already used in box columns and other structural parts. While maintaining good weldability, this product also has a low yield ratio, which is important from the viewpoint of earthquake resistance and is controlled to 80% or less in yield ratio by adopting the optimum chemical composition and special heat treatment. Because of development of the steel, JFE Steel was awarded the Okochi Memorial Technology Prize in 1992 and received the general approval of the Minister of Construction as SA440 in 1996. Orders received and manufactured already exceed 10 000 t. However, due to its high strength, conventional SA440 was subject to numerous restrictions in comparison with 490 N/mm<sup>2</sup> class steel, including limitations on the welding preheating temperature and bead length. For those problems, the improvement of weldability is required.

JFE Steel developed SA440-U with significantly improved weldability by reducing the carbon content to approximately 2/3 that of the conventional steel, while maintaining the outstanding properties of the existing steel (high strength, low yield ratio, high toughness). The developed steel exhibits the following advantages in comparison with the conventional steel.

(1) The preheating temperature can be reduced or pre-

heating work can be omitted.

- (2) The weld bead length in assembly welding (tack welding) can be shortened.
- (3) Deterioration in mechanical properties due to local heating is minimum.
- (4) Deterioration in mechanical properties due at butt welds and fitting welds is minimum.

Beginning immediately after the development, various advantages of developed steel were highly recognized by both steel frame manufacturers and designers, and HBL385 has already been adopted in a large number of projects. Orders received and manufactured have now reached more than 4 000 t.

In order to meet more recent requirements of high HAZ toughness in welds, JFE Steel also developed a 590 N/mm<sup>2</sup> class steel which has excellent toughness not only in beam-end welds, but also in members welded by high-efficiency ultra-high heat input methods, including corner welds in box columns (submerged arc welding) and diaphragm welds (electro slag welding), meeting toughness requirements of 70 J or higher at 0°C in steels from the 490 N/mm<sup>2</sup> class to 590 N/mm<sup>2</sup> class. These materials are produced using the JFE Steel's high HAZ toughness technology (JFE EWEL) which is being employed for ultra-high heat input welding of shipbuilding materials. JFE EWEL was realized through a fusion of JFE Steel's echnologies. Specifically, JFE EWEL utilizes TMCP technology, which is one of JFE Steel's advantages, and a reduced  $C_{eq}$  secured by TMCP,<sup>14)</sup> in combination with JFE Steel's high toughness technology for the HAZ,<sup>15)</sup> which consists of the refinement of prior  $\gamma$  grain size and promotion of ferrite nucleation through controlling of fine nitride, oxide, and sulfide particles, as well as suppression of brittle phases such as upper bainite microstructure (Fig. 10). JFE Steel has also developed welding consumables which satisfy high weld metal toughness requirements for use in submerged arc welding of corner welds and electro slag welding. And also JFE Steel can propose the optimum combination of steel materials, welding consumables,

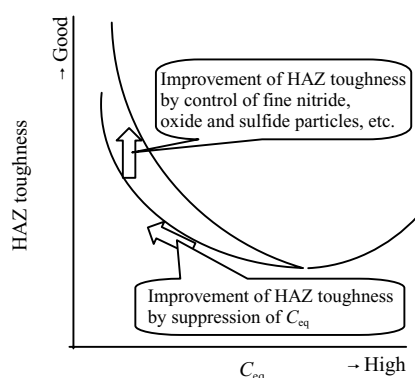

Fig. 10 Concept of improvement technology in HAZ toughness for high heat input welding

and welding techniques. HBL325 (490 N/mm<sup>2</sup> class) and HBL355 (520 N/mm<sup>2</sup> class) steels already have records of use in designated columns where high toughness in HAZ is required. In the future, JFE Steel will also encourage applications of HBL385 and SA440 to designated columns in high-rise buildings. It is believed that this can contribute to enhanced safety and reliability in these structures.

### 3.1.3 High durability Cr-added steel for building structural use “JFE410DH”

As one measure against global environmental problems, the Japanese government is now creating a legal system for a recycling-based society. The Green Procurement Law for government agencies has been enacted, and the Construction Recycling Law has taken effect in construction-related fields. Because there is an established recycling system for steels and corrosion resistance of steels can be secured by taking appropriate rust-prevention measures, steel products is one of the construction materials with low environmental-load. “Sustainable architecture” such as column and beam reuse methods for heavy steel frame members, long-life 3-generation housing, and recycling of steel from used housing has begun to expand to residential and other construction. However, steel products are typically rust-proofed by general painting or galvanizing, and therefore require touch-up painting at the constructing site and supplementary work such as curing at high-tensile bolt connections in some cases. Stainless steels such as Type 304A can now be used following the revision of the Building Standards Act and offers extremely high corrosion resistance without rust-proofing, but stainless steel products are expensive and design methods differ from those used with general carbon steel. As a result, stainless steel is still rarely used except in parts where appearance is a priority, such as entrance foyers.

JFE Steel therefore developed an 11% Cr steel for building structural use, JFE410DH, which has excellent corrosion resistance and uses the same design methods as general steel materials for building structural use, and has obtained material approval from the Minister of Land, Infrastructure and Transport (Jan. 28, 2002: MSTL-0071).

The mechanical properties of JFE410DH are controlled to be equivalent to those of 400 N/mm<sup>2</sup> class carbon steel for construction use by adopting appropriate techniques in the manufacturing process. In comparison with Type 304 stainless steel, which has an austenite structure, JFE410DH has a ferrite structure, giving it elasticity/rigidity, yield ratio, elongation, and other properties similar to those of 400 N/mm<sup>2</sup> class carbon steel. Furthermore, because its composition is designed to promote adequate formation of a fine martensite struc-



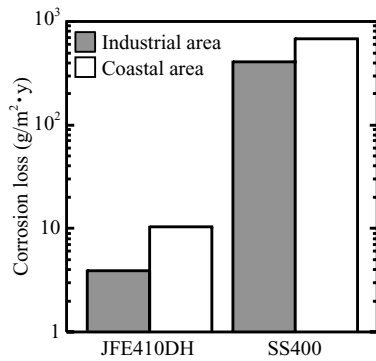

Fig. 11 Corrosion loss of JFE410DH and SS400 steels after one year field exposure test

ture, which has high toughness in welds, weld toughness is equal or superior to that of general steel materials for building structural use.

Due to its 11% Cr content, JFE410DH displays extremely high durability in atmospheric environments. **Figure 11** shows the results of a field exposure test. Corrosion loss with JFE410DH was 1/76 that of 400 N/mm<sup>2</sup> class carbon steel for construction use. According to the life-prediction formula for residential structural materials proposed by the Comprehensive Technical Development Project of the former Ministry of Construction,<sup>16)</sup> the life of 400 N/mm<sup>2</sup> class carbon steel with a 4.5 mm thickness is approximately 19 years, accordingly a simple proportional calculation shows that the life of JFE410DH is approximately 1 400 years.

There is also strong interest in the durability of structures among general consumers, as seen in the legal obligation to provide a 10-year guarantee against defects in the Law for Securing Quality in Residential Housing. As a steel product based on a new concept, JFE410DH is expected to be used not only as a steel for building structural use, which is now possible, but also in a variety of other applications which take advantage of its outstanding durability.

### 3.2 Tubular Products for Diverse Needs

#### 3.2.1 Rectangular hollow sections with abundant repertoires “JFE Column”

Rectangular hollow sections are widely used as column materials for building structural use. As shown in **Table 1**, this company’s product line, JFE Column, can be classified according to manufacturing methods as: (1) Cold roll-formed electric resistance welded rectangular hollow sections, (2) Cold press-formed submerged arc welded large-section, heavy-thickness rectangular hollow sections, P Column, which are manufactured and sold by Seikei Tube Works and Company and (3) Hot rolled seamless rectangular hollow sections. By yield point level, four classes are available (235, 295, 325, and 440 N/mm<sup>2</sup>).

Table 1 Rectangular hollow section columns

Process	Grade	YS (N/mm <sup>2</sup> )	TS (N/mm <sup>2</sup> )	YS (%)	vE <sub>0</sub> <sup>*1</sup> (J)
Cold roll	BCR295	295–445	400–550	≦90	27≦
Cold press	BCP235	235–355	400–510	≦80	27≦
	BCP325	325–445	490–610	≦80	27≦
	BCP325T	325–445	490–610	≦80	70≦ <sup>*2</sup>
	JPC440	440–540	590–740	≦80	47≦ (–40°C)
Seamless	STKR400-SH	245≦	400≦	–	–
	STKR490-SH	325≦	490≦	–	–

<sup>\*1</sup> Flat position, <sup>\*2</sup> Flat and corner positions,

YS : Yield strength, TS : Tensile strength,

YR : Yield ratio, vE<sub>0</sub> : Charpy absorbed energy at 0°C

BCR and BCP are rectangular hollow sections with improved weldability and plastic deformation performance in column materials for building structural use, and have been approved by the Minister of Land, Transportation and Infrastructure.

The newly developed high performance cold press-formed rectangular hollow section BCP325T has excellent toughness after cold press-forming due to use of a high performance base material with improved toughness, and offers guaranteed toughness of 70 J through the full cross-section. **Figure 12** shows the impact performance of flat and corner sections.

For use in large-scale structures such as super-high-rise buildings, JFE Steel developed 590 N/mm<sup>2</sup> cold press-formed rectangular hollow sections (JPC440).<sup>17)</sup> Like BCP325T, adequate toughness is possessed even in corner sections, and weldability and earthquake resistance are excellent, as shown in **Table 2** (the results of a bending test), and **Fig. 13** (the relationship between the diameter/thickness ratio and plastic deformation capacity (cumulative ductility factor) obtained in tests). These tests confirmed that this material does not rupture at the weld and possesses adequate strength and plastic deformation characteristics.

#### 3.2.2 High Strength Tubular Columns with Excellent Economy “P-325/355/385/440”

Because the shape and sectional performance of tubular columns are isotropic, beams can be attached from any angle. Moreover, when used as concrete-filled tubular columns, an increase in the compressive strength of the concrete can be expected due to the constraining force of the tube, making this a steel component with excellent economy.

JFE Steel’s high strength tubular columns for building structural use include four grades, as shown in **Table 3**. Although these products can be manufactured by either the UOE or press bending process, the

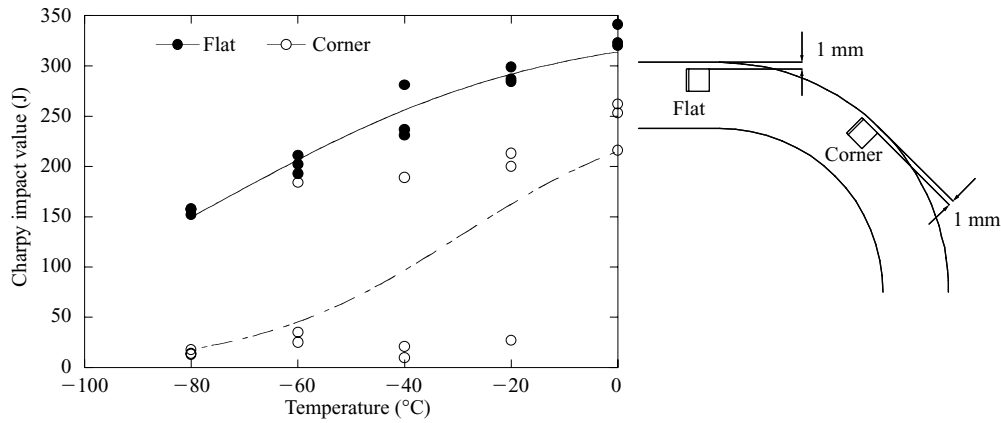

Fig. 12 Relation between Charpy impact value and temperature for BCP325T column at flat and corner positions

Table 2 Test results of bending test

Column size	Rank	$D/t$	(ex. $M_y$ )/(cal. $M_y$ )	(ex. $M_u$ )/(cal. $M_p$ )
□-600×19	FC	31.6	1.02	1.20
□-600×25	FB	24.0	1.02	1.40
□-600×40	FA	15.0	1.02	1.49

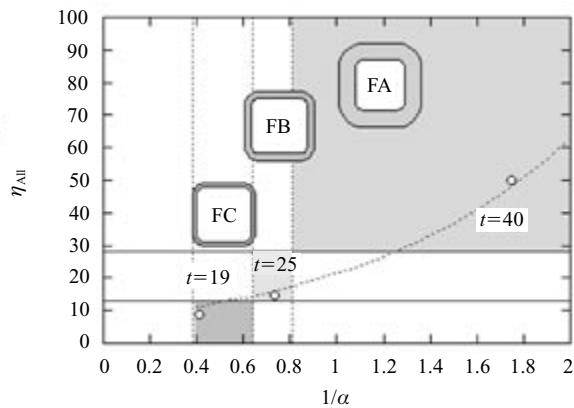

Fig. 13 Relationship between diameter-width ratio and cumulative ductility factor

Table 3 Mechanical properties of tubular column

Grade	YS (N/mm <sup>2</sup> )	TS (N/mm <sup>2</sup> )	YR (%)	vE <sub>0</sub> (J)
P-325B, C	325-475	490-610	≧85	27≧
P-355B, C	355-505	520-640	≧85	27≧
P-385B, C	385-535	550-700	≧85	70≧
P-440B, C	440-590	590-740	≧85	47≧

manufacturing process is determined by the thickness/diameter ratio ( $t/D$ ), as shown in Fig. 14, in order to satisfy yield ratio requirements.<sup>18)</sup>

P-385 is a tubular column of an exclusive JFE Steel's strength level. Figure 15 shows the results of a bending test ( $D/t = 24$ , FA rank). Failure did not occur at the weld, and strength was ultimately reduced by local buck-

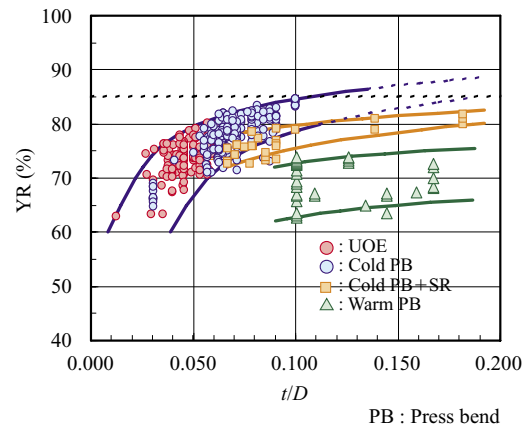

Fig. 14 Influence of tube forming on yield ratio

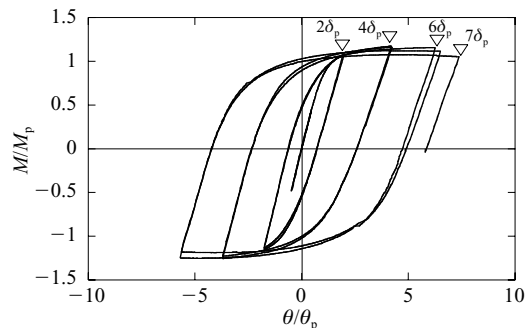

Fig. 15 Bending moment ( $M$ ) - angle of member rotation ( $\theta$ ) relation

ling of the tube, showing that the product possesses the necessary plastic deformation capacity.

### 3.3 Large Section/High Strength Wide Flange H-Shapes

#### 3.3.1 Large section fixed outer dimension H-shapes "Super Hislend-H"

JFE Steel began marketing fixed outer dimension H-shapes "Super Hislend-H" (SHH) in Nov. 1989 and subsequently expanded the available size range to include a maximum of 42 nominal size and 292 individual sizes domestically at present, as shown in Fig. 16.

Commercialization of large section H-shapes, such

		(mm)				
Width \ Depth	200	250	300	350	400	
400	◇					◇ Common size ● JFE Steel original size
450	◇	◇				
500	◇	◇	●			
550	◇	◇	●			
600	◇	◇	◇			
650	◇	◇	●			
700	◇	◇	◇	●		
750		◇	●	●		
800		◇	◇	●	●	
850		◇	◇	●	●	
900		◇	◇	●	●	
950		●	●	●	●	
1 000		●	●	●	●	

Fig. 16 Size variety of Super Hislend-H

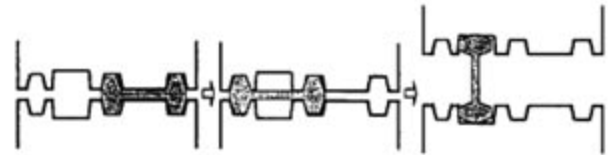

Fig. 17 Rolling method of breakdown mill

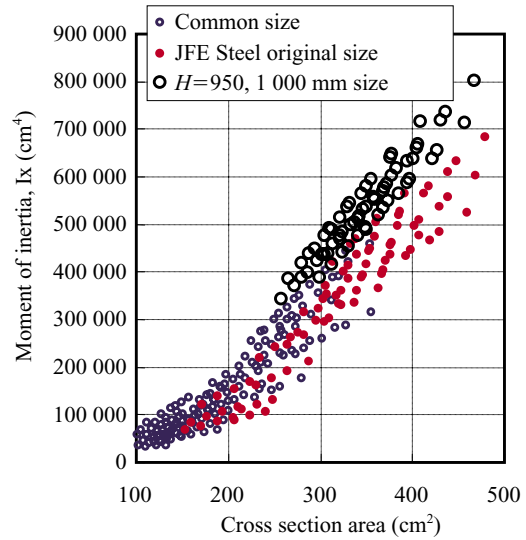

Fig. 18 Relation between moment of inertia and cross section area for Super Hislend-H

as web heights of 1 000 mm and 950 mm in Feb. 1999,<sup>19)</sup> was realized by expanding the capacity of the intermediate rolling mills in the modernization of the steel shape mill at Kurashiki District of West Japan Works completed in June 1996, and development of caliber rolling technology, an example of which is shown in Fig. 17. The relationship between the cross-sectional area and moment of inertia of each size is shown in Fig. 18. In SHH with web heights of 950 mm and 1 000 mm, sectional efficiency is improved by approximately 50% in comparison with SHH with web heights of 900 mm and less.

### 3.3.2 TMCP heavy wide flange H-shapes “HBL-JH325/355”

Application of TMCP to the manufacture of H-shapes allowed JFE Steel to develop TMCP heavy gauge H-shapes, HBL-JH325/355, with the product specifications shown in Table 4. Commercial production began in 1995. As with TMCP steel plates, these shape

products have been approved under Article 37 of the Building Standard Law. Two design standard strength grades are available, 325 and 355 N/mm<sup>2</sup>.

In Nov. 1998, JFE Steel also began standard production of heavy wide flange H-shapes in 700 × 500 nominal size, which feature excellent sectional efficiency, to meet the need for heavier sections.<sup>20)</sup> As shown in Fig. 19, in contrast to the 500 × 500 nominal size, the inside web height in the 700 × 500 nominal size has been increased by approximately 150 mm, giving the

Table 4 Specification of HBL-JH325/355

Specification		Chemical composition (mass%)					C <sub>eq</sub> (%)	P <sub>CM</sub> (%)	Mechanical property									
		C	Si	Mn	P	S			YS (N/mm <sup>2</sup> )	TS (N/mm <sup>2</sup> )	YR (%)	El (%)	Thru-thickness reduction of area(%)	vE <sub>0</sub> (J)				
HBL-JH325B	40 < t ≤ 50	0.18	≤ 0.55	≤ 1.60	≤ 0.030	≤ 0.015	≤ 0.38	≤ 0.24	325– 445	490– 610	≤ 80	21 ≤	–	27 ≤				
	50 < t	0.20					≤ 0.40	≤ 0.26				No.1A						
HBL-JH325C	40 < t ≤ 50	0.18	≤ 0.55	≤ 1.60	≤ 0.020	≤ 0.008	≤ 0.38	≤ 0.24								23 ≤	25 ≤ <sup>*1</sup>	
	50 < t	0.20					≤ 0.40	≤ 0.26								No.4	15 ≤ <sup>*2</sup>	
HBL-JH355B	40 < t ≤ 50	0.20	≤ 0.55	≤ 1.60	≤ 0.030	≤ 0.015	≤ 0.40	≤ 0.26	355– 475	520– 640	≤ 80	19 ≤	–	27 ≤				
	50 < t						≤ 0.42	≤ 0.27				No.1A						
HBL-JH355C	40 < t ≤ 50	0.20	≤ 0.55	≤ 1.60	≤ 0.020	≤ 0.008	≤ 0.40	≤ 0.26								21 ≤	25 ≤ <sup>*1</sup>	
	50 < t						≤ 0.42	≤ 0.27				No.4	15 ≤ <sup>*2</sup>					

<sup>\*1</sup>Average for three pieces,

<sup>\*2</sup>For each test value,

P<sub>CM</sub> = C+Si/30 + (Mn + Cu + Cr)/20 + Mo/15 + Ni/60 + V/10 + 5B, El : Elongation,

vE<sub>0</sub> : Charpy absorbed energy at 0°C

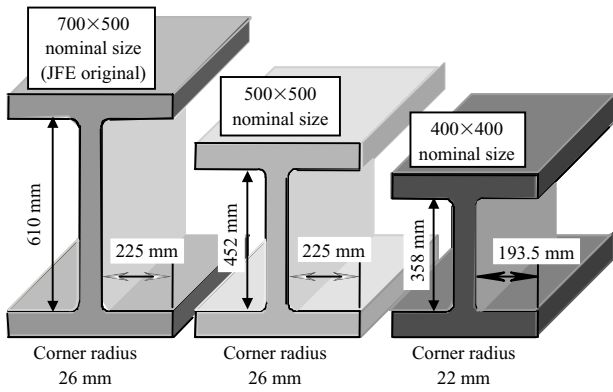

Fig. 19 Inside dimensions of heavy wide flange H-shapes

Table 5 Structural performance and weight of column

Nominal size		Rectangular hollow section	700×500 nominal size	500×500 nominal size
Displacement (cm)	X-direction	41.09	42.08	43.77
	Y-direction	40.51	39.70	41.88
Weight of column (%)		100	99	98

new product a section secondary moment 1.5 to 2 times larger than the existing series with the same sectional area.

Table 5 shows a comparison of column weight when large section H-shape column materials, which do not require a reduction in the design standard strength, and box columns (rectangular hollow sections) are applied in a structure 165 m high with 35 aboveground stories. The weight of the H-shape columns is approximately 2–3% less than that of the rectangular hollow sections. In particular, the 700 × 500 nominal size is the most efficient section shape.

### 3.3.3 TS 550 N/mm<sup>2</sup> wide flange H-shapes for building structure “HBL-H385”

In 2000, JFE Steel developed a TMCP TS 550 N/mm<sup>2</sup> wide flange H-shape with a design standard strength of 385 N/mm<sup>2</sup>.<sup>14)</sup> This product, HBL-H385, was realized by JFE Steel’s state-of-the-art TMCP device for shape steel (*Super-OLAC S*) and advanced manufacturing and quality control technologies. Available section sizes include those specified for JIS H-shapes and fixed outer dimension H-shapes.

Product specifications are shown in Table 6. In comparison with SN490, the yield strength and tensile strength are increased by 60 N/mm<sup>2</sup>, while  $C_{eq}$  and  $P_{CM}$  are held to the same levels. Therefore, when applied

in structures, a section reduction of 1–2 sizes can be achieved in comparison with TS490 N/mm<sup>2</sup> wide flange H-shapes, while welding costs in frame fabrication are also lower, substantially reducing construction costs. As shown in Table 7, adequate impact performance is secured in CO<sub>2</sub> gas metal arc welds, showing that performance requirements for beam-end welded joints can be fully satisfied even in a cyclic loading test of beam-to-column joints.<sup>21)</sup>

Next, in many cases, steel reinforced concrete (SRC) structures function advantageously with high strength steel materials, for example, by providing high rigidity and buckling resistance in comparison with steel frame structures. However, because some points remain to be clarified, such as the effect of the strength difference between steel and concrete, JFE Steel’s researchers conducted cyclic bending loading tests under the axial load of the SRC structures column. An example of the test results is shown in Fig. 20. The strength obtained in these tests satisfied the equation for calculation of SRC structures criteria,<sup>22)</sup> confirming that the equation for these criteria can also be applied to this steel grade.

Table 7 Charpy impact test result of CO<sub>2</sub> welded joint

Test position	vE <sub>0</sub> (J)	
	Each	Average
Weld metal	134	163
	170	
	183	
Bond	213	183
	179	
	159	
Bond +1 mm	234	231
	228	
	232	
Bond +3 mm	225	238
	241	
	249	

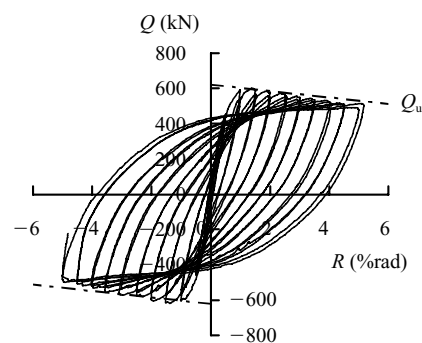

Fig. 20 Relation between bending load and displacement for SRC column under axial load

Table 6 Mechanical properties of HBL-H385

Grade	YS (N/mm <sup>2</sup> )	TS (N/mm <sup>2</sup> )	YR (%)	vE <sub>0</sub> (J)	C <sub>eq</sub> (%)	P <sub>CM</sub> (%)
HBL-H385B	385-505	550-670	≦80	≧70	≦0.44	≦0.29
SN490B	325-445	490-610	≦80	≧27	≦0.44	≦0.29

### 3.4 High Earthquake Resistance Construction Methods

#### 3.4.1 Low yield strength steel dampers

Dampers using low yield strength steel positively absorb the energy introduced into structures by earthquakes and are effective in reducing the response of the structure.

The low yield strength steel used in dampers must have a low yield proof stress in comparison with carbon steel, and deviations in yield strength must be more strictly controlled. The steel is also required to have sufficient ductility and toughness to withstand cyclical plastic deformation during earthquakes.

As shown in **Table 8**, JFE Steel’s line of low yield strength steels includes a total of 5 types, with 3 grades of plate and 2 grades of seamless pipe.

Dampers are broadly classified as the shear yield type or axial yield type. JFE Steel has commercialized wall dampers, shear panel dampers, and brace dampers of these respective types.<sup>23,24)</sup>

Table 8 Mechanical properties of steel plates and seamless pipes with low yield strength

	Grade	YS (N/mm <sup>2</sup> )	TS (N/mm <sup>2</sup> )	YR (%)	EI (%)
Plate	JFE-LY100	100±20	200-300	≦60	≧50
	JFE-LY160	160±20	220-320	≦80	≧45
	JFE-LY225	225±20	300-400	≦80	≧40
Seamless pipe	RF100-S	100±20	200-280	≦60	≧50
	RF225-S	225±20	300-400	≦80	≧35

JFE Steel manufactures 2 types of brace dampers, as shown in **Fig 21**. In the double tube steel bracing in Fig. 21 (a), an outer reinforcing tube is used to restrain the buckling of the inner axial-force tube. In the flat-bar brace stiffened by square tube in Fig. 21 (2), a rectangular hollow section is used for buckling restraint of the brace axial material, which consists of flat bars.

**Figure 22** shows a comparison of the hysteresis characteristics of a conventional steel tube brace and a JFE Steel’s brace damper. In both rigidity and strength, the brace damper has stable historical characteristics, displaying equal compression and tension, and thus has a high plastic deformation capacity.

#### 3.4.2 New joining method for beam-to-column joints at steel pipe column-H-shape beam connections “Earthquake Resisting Joint”

Earthquake Resisting Joint is a joining method developed exclusively by JFE Steel to prevent brittle fracture at beam ends by improving joint details and does not require complex design/welding control. The method includes two types of joints, a bolt joint type (TJB) for the bracket method and a welded joint type (TJW) for field welding.

In the TJB shown in **Fig. 23(a)**, the diaphragm and bracket flange are formed by a single plate, and the width of the bracket flange is increased corresponding to the moment gradient. Because position at the first bolt hole on the beam side furthest from the column is the weakest section, energy is absorbed by the beam base material, which has high ductility, to secure a

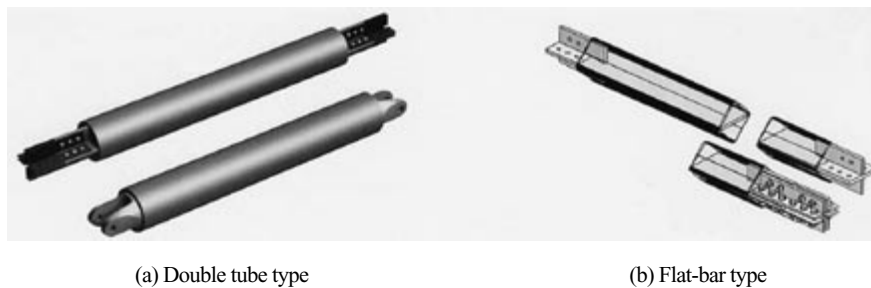

Fig.21 Type of brace damper

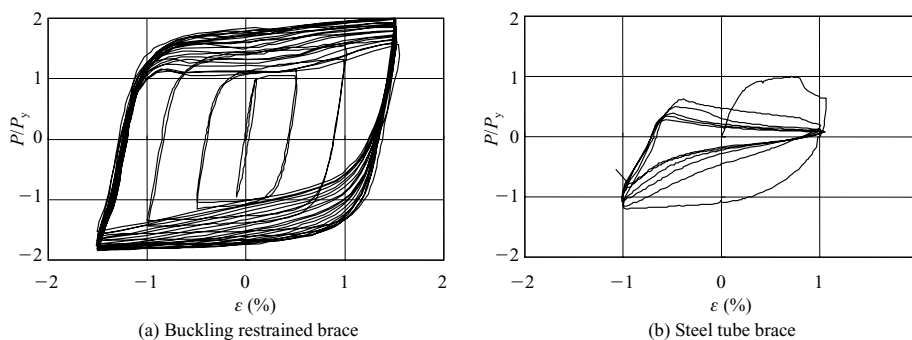

Fig.22 Relations between non-dimensional axial load and displacement for buckling restrained and steel tube braces

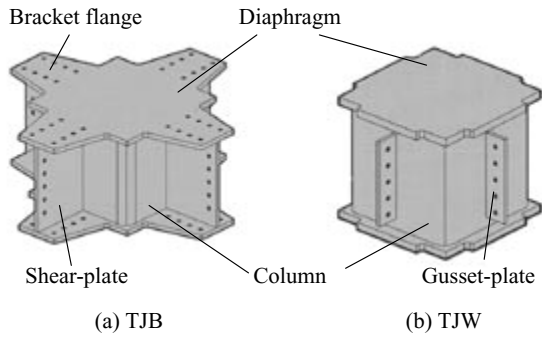

Fig. 23 Schematic of earthquake resistant joint

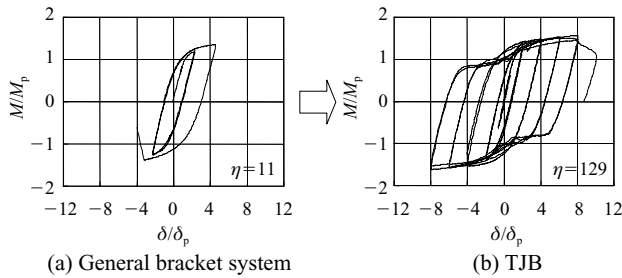

Fig. 24 Comparison in hysteresis curve for two different type of earthquake resistant joint

high deformation capacity, as shown in Fig. 24.<sup>25)</sup> Other advantages include a reduction of diaphragm thickness by being formed with single plate, less difficult welding control requirements, improved transportation efficiency, and reduced joint fabrication costs.

The TJW shown in Fig. 23 (b) has a protruding part with a curved reentrant at the position where the diaphragm is attached to the beam flange, avoiding welding defects at the beginning and end of the weld line and stress/strain concentrations, and greatly increases the deformation capacity.

An integrated design program has been prepared for both of these joints, which makes it possible to obtain outputs from designs to drawing preparation and totaling from simple inputs. In addition to fabrication and marketing by processing contractors introduced by JFE Steel, the fabricator receiving the order can also manufacture this product.

### 3.4.3 Column-to-pile direct connection “Ichi-ichi Foundation Method”

As a new connection method for structures and piles, JFE Steel has developed a foundation method called the Ichi-ichi Foundation Method, in which a steel pipe column is embedded in a pile-top portions of cast-in-place concrete-filled steel pipe piles, and H-shape beams are used as foundation beams (Fig. 25).

This method secures a high deformation capacity and earthquake resistance, as shown in Fig. 26, because the positions where hinge occurs are limited to the ductile steel flange by designing the connections to meet

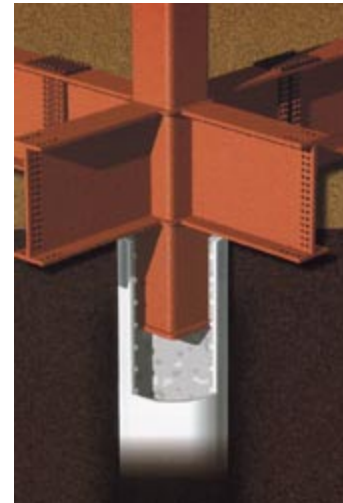

Fig. 25 Outline of pile to column direct connection

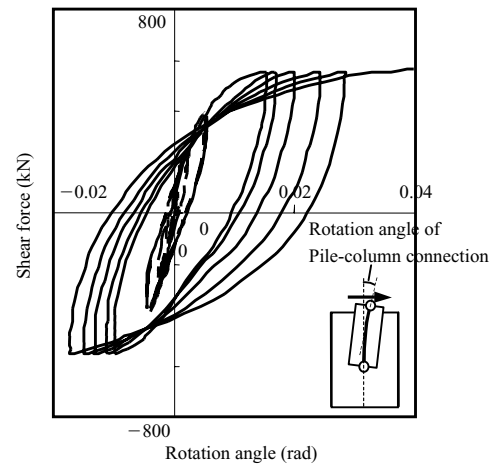

Fig. 26 Q-θ relation of specimen

moment-connection requirements. Furthermore, because an ordinary footing is not required, the height of the foundation beams can be decreased, reducing the amount of soil excavated, decreasing costs, and shortening the required construction period.

As a design technique for this construction method, a unique design formula was constructed based on a large number of structural loading tests<sup>26)</sup>, and passed technical appraisal by General Building Research Corp. of Japan (No.02-10). This method has already been applied in 5 construction projects.

## 4. Common Materials

### 4.1 Environment-friendly Construction Products

#### 4.1.1 Recycled slag as construction materials

This section describes environment-friendly construction products made from slag, which is a byproduct of the iron and steel manufacturing processes.

**Figure 27** shows slag products for port and harbor construction and restoration of coastal environments. “Ferroform” is a hydration-hardened solid which is produced from iron and steel slag and contains absolutely no cement or natural aggregate. While showing the same strength as concrete, alkaline elutes are minimal, and formation of marine life on the material is good, giving this product numerous advantages as a block or stone material for ports and harbors. “Marine Block” is a porous block in which CO<sub>2</sub> gas is absorbed and fixed in steelmaking slag and shows satisfactory seaweed growth, making it a good seaweed bed material. Because CO<sub>2</sub> gas is absorbed in the manufacturing process and is also fixed by seaweed, this material contributes to prevention of global warming. “Granulated blast furnace slag sand capping material” is a sand-like material for sea bottom improvement which suppresses sulfuric acid-reducing bacteria and does not cause the environmental damage associated with natural sand extraction.

As a product for improving the urban environment, JFE Steel developed a “water-retaining paving material” for mitigation of the heat island phenomenon. This material is produced by injecting and hardening a slurry consisting mainly of fine particles of blast furnace slag in the voids in a porous asphalt compound for water-permeable pavement or similar applications. After rain, a large amount of water is retained in the interior of the formed porous material. This moisture is gradually released, cooling the pavement by heat of vaporization, and has the effect of reducing road surface temperatures by 17°C in summer.

#### 4.1.2 Concrete forms manufactured from recycled resin “NF Board”

Based on the concept of creating an environment-friendly future, in 2002, JFE Steel began manufacturing a concrete form called NF Board (new future, frontier, friendly) as a new recycling business, using recycled plastic as the main raw material. Because NF Board has a multi-layer structure with a foam center layer, it is both lightweight and strong, realizing the same easy handling as conventional plywood and improved workability. By contributing to reduced logging in the South Sea Islands, which is the source of material for wooden boards, it is also a global environment-friendly product. NF Board has the following advantages:

- (1) Excellent durability in comparison with wooden boards (plywood). The number of times the board can be reused is greatly extended, reducing total costs.
- (2) Can be processed in the same way (cutting, drilling, nailing) as plywood using the same tools.
- (3) Lightweight, with approximately the same weight as plywood, and easy to handle, with easy form removal properties.
- (4) A system for recovering end-of-life boards and recycling the waste plastic as blast furnace feed has been established.

NF Board is marketed by Green Materials Recycle Corp., which was established with joint investment by three of Japan’s leading general contractors, Kajima Corp., Taisei Corp., and Shimizu Corp. Since the factory was completed in Sep. 2002, NF Board has been shipped

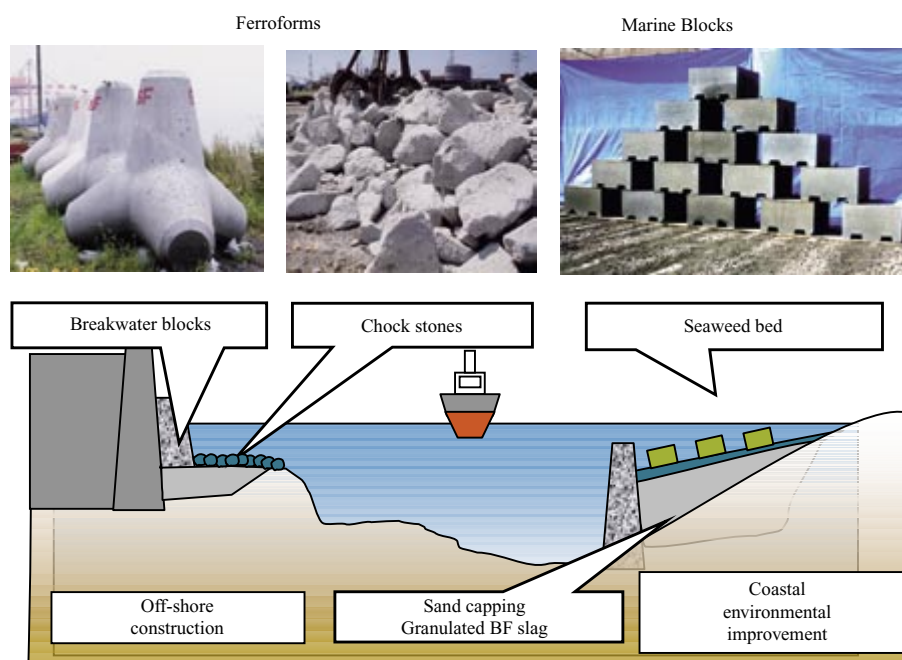

Fig.27 Products made from slag for off-shore construction and coastal environmental improvement

to more than 120 customers (as of Apr. 2003).

As a recycled form, this product has received Approval of Innovative Building technologies from the Building Center of Japan.

## 4.2 High Strength Shear Reinforcing Bars for Improved Earthquake Resistance

### 4.2.1 High strength shear reinforcing bar “Riverbon”

In response to demand for improved earthquake resistance in recent years, high strength steel reinforcing bars have been used in place of ordinary carbon steel rebar in an increasing number of cases in shear reinforcing bars for columns and beams in reinforced concrete buildings and in shear reinforcing bars for elevated bridge columns and piers in civil structures. High strength steel is necessary because it is difficult to satisfy the quantitative requirements for shear reinforcing bars with ordinary rebar of YS295 N/mm<sup>2</sup> class due to the axial force and high shear force requirements of improved earthquake resistance.

JFE Techno-wire therefore developed high strength shear reinforcing bars in two yield strength classes, Riverbon 785 and Riverbon 1275.<sup>27)</sup> Utilizing the features of these respective new products, as discussed below, it is possible to meet diverse design and execution requirements.

Riverbon 785 and Riverbon 1275 have yield strengths of 785 N/mm<sup>2</sup> and 1 275 N/mm<sup>2</sup> and have been rated by the Building Center of Japan in the applicable range of concrete strengths from 21 N/mm<sup>2</sup> to 60 N/mm<sup>2</sup>. In addition to fabrication with bending forming, fabrication in welded hoops is also possible. In particular, the weld profile with Riverbon 1275 has extremely small bulging at welds so as not to interfere with main reinforcing bars during bar setting. In the innovative multi spiral hoop of Riverbon 1275<sup>28)</sup> (Photo 9), the outer hoop and inner rods are formed continuously from a single piece of material, reducing hoop weight and the number of hook parts, and thereby simplifying rebar setting work.

In JFE Techno-wire Design and Execution Guidelines, a plasticity theory equation was proposed for Riverbon 785,<sup>29)</sup> while 2 design equations, the Arakawa equation and a plasticity theory equation, were proposed for Riverbon 1275,<sup>30,31)</sup> confirming the safety of these two products. In particular, JFE Techno-wire has established a unique design equation for Riverbon 1275 based an enormous volume of experimental and analytical results, allowing Riverbon 1275 to demonstrate its superiority when used with high strength concrete. This product can be utilized in a wide range of applications, from medium- to ultra-high-rise reinforced concrete structures.

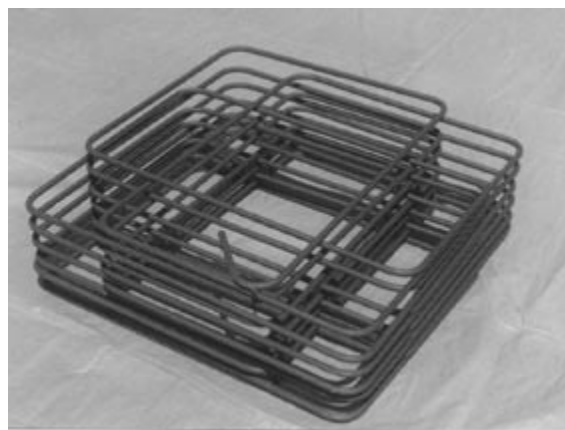

Photo 9 Riverbon 1275 multi spiral hoop



Photo 10 Riverren

### 4.2.2 Beam penetration opening reinforcing bar “Riverren”

Beams with penetration opening must provide the same performance as solid beams. Because the reinforcing material for these holes, Riverren,<sup>32)</sup> (Photo 10) is a YS1275 N/mm<sup>2</sup> reinforcing bar, this is not a structurally weak part and demonstrates uniform performance. Thinner reinforcement can be used and the number of pieces is reduced in comparison with conventional reinforcing bars, greatly simplifying reinforcement setting work.

## 5. Conclusions

Construction products must solve a diverse range of problems. For example, materials and methods must meet earthquake-resistance requirements and environmental standards, and labor-saving and reduced construction costs are necessary at construction sites with various restrictive conditions such as limited working areas and overhead obstacles. In developing construction products, JFE Steel and members of the JFE Steel Group listen to the needs of society and the times and take a broad view of the market, while also recognizing the importance consistently creating new breakthrough



technologies with strategic value.

## References

- 1) Mori, G.; Shinohara, T.; Hayashi, M. The Foundation Engineering & Equipment, Monthly, vol.28, no.12, 2000, p.71–75.
- 2) Okubo, H.; Nishizawa, S.; Mitani, Y. Construction and structural characteristics of steel pipe sheet pile composite foundation method for large-scale bridge. *Kawasaki Steel Giho*. vol.34, no.4, 2002, p.33–39.
- 3) Ishizawa, Takeshi et al. Steel retaining wall “K-Domeru”. *Kawasaki Steel Giho*. vol.24, no.3, 1992, p.24–32.
- 4) Miura, Hironori et al. Application of jointed element structure steel shapes having excellent fatigue characteristics. *Kawasaki Steel Giho*. vol.34, no.4, 2002, p.188–194.
- 5) Shimizu, Mitsuru; Fujimoto, Hideki; Muraki, Yasuyuki. Rail line under of Japan Railway Company at steel pipe piles driving method for underpinnings. *Kisokou*. vol.29, no.10, 2001, p.50–54.
- 6) Sakaguti, Y.; Nakagawa, T. The Foundation Engineering & Equipment. vol.30, no.5, 2002, p.38–42.
- 7) Japan Road Association. Specification for Highway Bridges Part IV. 2002-03.
- 8) Japan Road Association. *Koukanyaitakiso Sekkei Sekou Binran*. 1997.
- 9) Coastal Development Institute of Technology. *Strutted Frame Method Technical Manual*. Tokyo, 2000, p.229 (ISBN 4-900302-48-1).
- 10) Waterfront Vitalization and Environment Research Center. *Kanrigata Haikibutsu Umetate Gogan Sekkei-Sekou-Kanri Manyuaru*. Tokyo, 2000, p.86 (ISBN4-925221-05-1).
- 11) Toyohara, H.; Usui, K.; Okita, K. Threaded joints “Mechaneji” for landslide preventive steel pipe pile. *Kawasaki Steel Giho*. vol.30, no.4, 1998, p.19–24. (in Japanese).
- 12) SABO Technical Center. *Mechanical Joints for Landslide Preventive Steel Pipe Pile*. 2000. (in Japanese)
- 13) SABO Technical Center. *Threaded Joints “Mecha-Neji” for Landslide Preventive Steel Pipe Pile*. 1997. (in Japanese)
- 14) Sumi, Hiroyuki. High performance steel for building (Development of 550 N/mm<sup>2</sup> class steel plate for building structure). *CAMP-ISIJ*. vol.16, 2003, p.344–347.
- 15) Kimura, Tatsumi. Steel plates for architectural construction with excellent toughness in large heat input welded joints. *Kawasaki Steel Technical Report*. vol.34, no.4, 2002, p.158–163.
- 16) Ministry of Construction. Report of General Technology Development Project, “Development of Technology for Improving Buildings’ Durability”. 1985.
- 17) Inosaka, T. et al. “Structural performance of 590 N/mm<sup>2</sup> cold press-formed rectangular column Part 1, Part 2”. *Summaries of Technical Papers of Annual Meeting Architectural Institute of Japan*. 2002.
- 18) Wada, T. et al. High performance tubular column with exterior ring-diaphragms for building structure “NT Column”. *NKK Technical Report*. no.157, 1997, p.37–43.
- 19) Kawamura, Arihide et al. Fixed outer dimension H-shapes. *Kawasaki Steel Giho*. vol.33, no.3, 2001, p.128–131.
- 20) Miura, Hironori et al. Development of heavy wide flange H-shapes “700 × 500 nominal size” for building structure. *Kawasaki Steel Giho*. vol.33, no.3, 2001, p.132–136.
- 21) Nakamura, Nobuyuki et al. “Experimental study on elastic-plastic behavior of SRC column with high strength steel (part 1)-(part 3)”. *Summaries of Technical Papers of Annual Meeting Architectural Institute of Japan*, C-1, 2003, p.1047–1052.
- 22) Architectural Institute of Japan. *Standard for Structural Calculation of Steel Reinforced Concrete Structure*. 2001, p.11–16.
- 23) Fujisawa, K. et al. Performance of hysteretic dampers using low yield stress steel. *Kawasaki Steel Giho*. vol.30, no.1, 1998, p.1–6.
- 24) Ito, S. et al. Hysteretic energy dissipation devices with low yield strength steel for passive structural control. *NKK Technical Report*. no.170, 2000, p.67–74.
- 25) Okamoto, Haruhito et al. Development of earthquake resisting joint. *NKK Technical Report*. no.178, 2002, p.58–62.
- 26) Konno, Kazuchika et al. “Study on behavior of steel tube column to concrete-filled pipe pile with rigid connection Part 1 to Part 5”. *Summaries of Technical Papers of Annual Meeting Architectural Institute of Japan*. C-3, 2002, p.813–822.
- 27) Kanasugi, Hideki; Nakazawa, Atsushi; Miyakoshi, Shohei. High-strength shear reinforcement and high-strength opening reinforcement. *Kawasaki Steel Giho*. vol.30, no.1, 1998, p.65–68.
- 28) Nakazawa, Atsushi; Shibata, Masataka; Watababe, Ikuo; Shiraiishi, Tamaki; Mihara, Juro. Configurational effects of high-strength transverse reinforcement on ductility behavior reinforced concrete members—Development of Riverbon MULTI SPIRAL HOOPS—. *Kawasaki Steel Giho*. vol.24, no.3, 1992, p.177–183.
- 29) JFE Techno-wire Corp. Design and execution guideline and explanation of reinforced concrete members using high-strength shear reinforcement bar “Riverbon 785”. 2002.
- 30) JFE Techno-wire Corp. Design and execution guideline and explanation of reinforced concrete members using high-strength shear reinforcement bar “Riverbon 1275”. 2002.
- 31) Shibata, Masataka; Nakazawa, Atsushi; Shiraiishi, Tamaki; Yamamoto, Noboru; Kosaka, Kiyoshi; Shiga, Katsutoshi. Development of super-high-strength shear reinforcement for structural reinforced concrete members. *Kawasaki Steel Giho*. vol.23, no.2, 1991, p.112–118.
- 32) JFE Techno-wire Corp. High-strength beam penetration opening reinforcement bar “Riverren” (Design and execution guideline and explanation). 2002.